

CITY OF HORICON

404 E Lake Street
Horicon WI 53032

MEETING NOTICE

DATE ISSUED: April 25, 2023

BY: Bryce Remy

PARK AND RECREATION BOARD

ATTENDEES: Bryce Remy	Richard Marschke	Jerry Voy	
Josh Muche	Jenny Krueel	Cody Vanderhei	C: Mayor Maas
Carson Roseliep, Recreation Director		Drew Buteyn, YMCA Aquatic Director	

DATE: Monday, May 1, 2023

TIME: 6:00 p.m.

LOCATION: Kiwanis Park Pavilion

LEADER: Bryce Remy, Chairperson

AGENDA:

1. Call to Order.
2. Roll Call.
3. Approve Previous Minutes
4. Public Appearances.
Limited to 3 Minute Time Frame Per Individual
5. Parks Report.
6. Aquatic Center Report.
7. Recreation Report.
8. Request by Horicon/Mayville Chamber of Commerce for 5K Event at Discher Park.
9. Kiwanis Park Open Air Structure Replacement.
10. Updates on Discher Dance Hall.
11. Updates on Bowling Green Park Memorial.
12. Parks and Recreation Board Goals and Priorities.
13. Set Next Meeting Date/Place.
14. Adjourn.

IF UNABLE TO ATTEND, PLEASE NOTIFY: Bryce Remy **PHONE NUMBER:** 920-915-1081
DATE POSTED: April 25, 2023 **TIME POSTED:** 2:00 p.m.

It is possible that members of and a possible quorum of members of governmental bodies of the municipality, other than the Park & Recreation Board, may attend the above event. No action will be taken by any governmental body, other than the Park & Recreation Board, at the above event.

Application for Temporary Class "B" / "Class B" Retailer's License

See Additional Information on reverse side. Contact the municipal clerk if you have questions.

FEE \$ 10⁰⁰

Application Date: 4/17/23

Town Village City of Horicon

County of Dodge

The named organization applies for: (check appropriate box(es).)

A Temporary Class "B" license to sell fermented malt beverages at picnics or similar gatherings under s. 125.26(6), Wis. Stats.

A Temporary "Class B" license to sell wine at picnics or similar gatherings under s. 125.51(10), Wis. Stats.

at the premises described below during a special event beginning June 3 2023 and ending June 3 2023 and agrees to comply with all laws, resolutions, ordinances and regulations (state, federal or local) affecting the sale of fermented malt beverages and/or wine if the license is granted.

1. **Organization** (check appropriate box) → Bona fide Club Church Lodge/Society

Chamber of Commerce or similar Civic or Trade Organization

Veteran's Organization Fair Association

(a) Name Horicon Chamber of Commerce

(b) Address PO Box 23, Horicon WI 53032
(Street) Town Village City

(c) Date organized 6/3/23

(d) If corporation, give date of incorporation _____

(e) If the named organization is not required to hold a Wisconsin seller's permit pursuant to s. 77.54 (7m), Wis. Stats., check this box:

(f) Names and addresses of all officers:

President Kristine Mattila

Vice President Amy Kuttman

Secretary Kristine Mattila

Treasurer Kristine Mattila

(g) Name and address of manager or person in charge of affair: Kristine Mattila
PO Box 23, Horicon WI 53032

2. **Location of Premises Where Beer and/or Wine Will Be Sold, Served, Consumed, or Stored, and Areas Where Alcohol Beverage Records Will be Stored:**

(a) Street number 800 N Finch St, Horicon WI 53032

(b) Lot _____ Block _____

(c) Do premises occupy all or part of building?

(d) If part of building, describe fully all premises covered under this application, which floor or floors, or room or rooms, license is to cover:

3. **Name of Event**

(a) List name of the event SK for Heroes Run, Walk + Roll Afterparty

(b) Dates of event June 3 2023

DECLARATION

The Officer(s) of the organization, individually and together, declare under penalties of law that the information provided in this application is true and correct to the best of their knowledge and belief.

Horicon Chamber of Commerce
(Name of Organization)

Officer [Signature] 4/17/23
(Signature/date)

Officer _____
(Signature/date)

Officer [Signature] 4/17/23
(Signature/date)

Officer _____
(Signature/date)

Date Filed with Clerk 4/17/23

Date Reported to Council or Board _____

Date Granted by Council _____

License No. _____

COPYRIGHT 2023
 The information shown within this drawing is the intellectual property of Scenic Shelter, not be copied or disclosed to any unauthorized parties in part or its entirety without our written permission, and they shall not be used for construction.

NOTES:

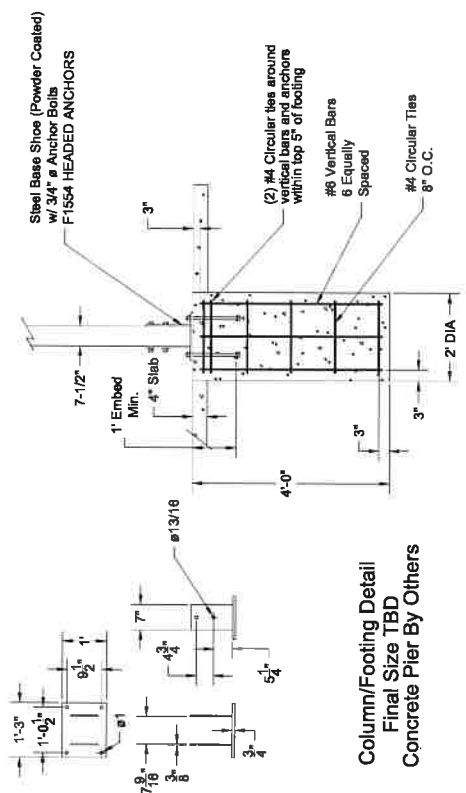

Column/Footing Detail
 Final Size TBD
 Concrete Pier By Others

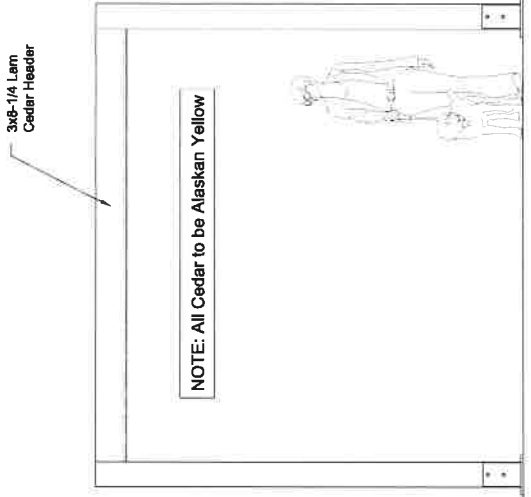
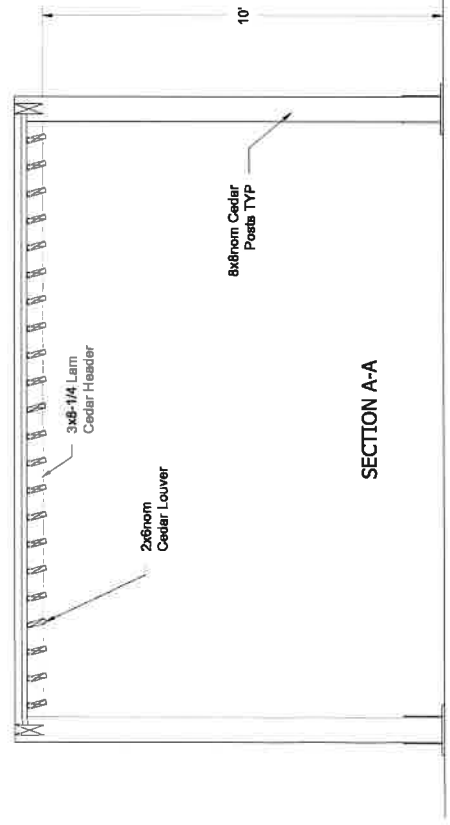
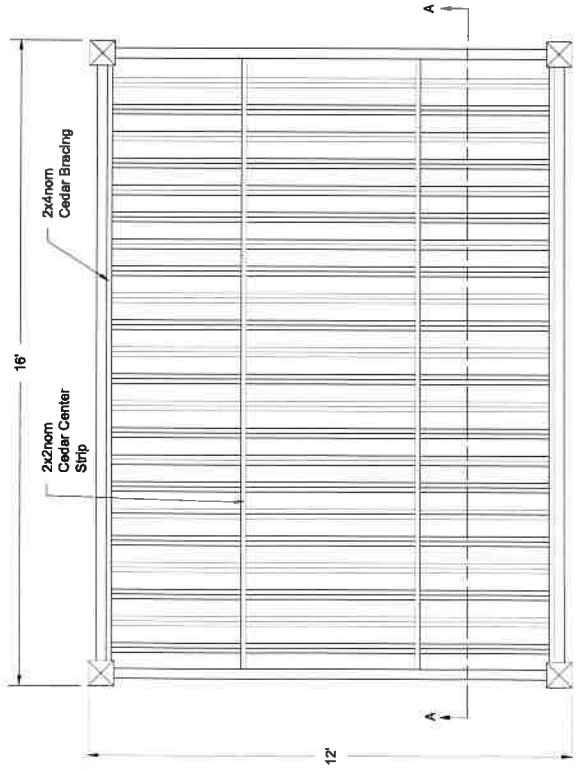

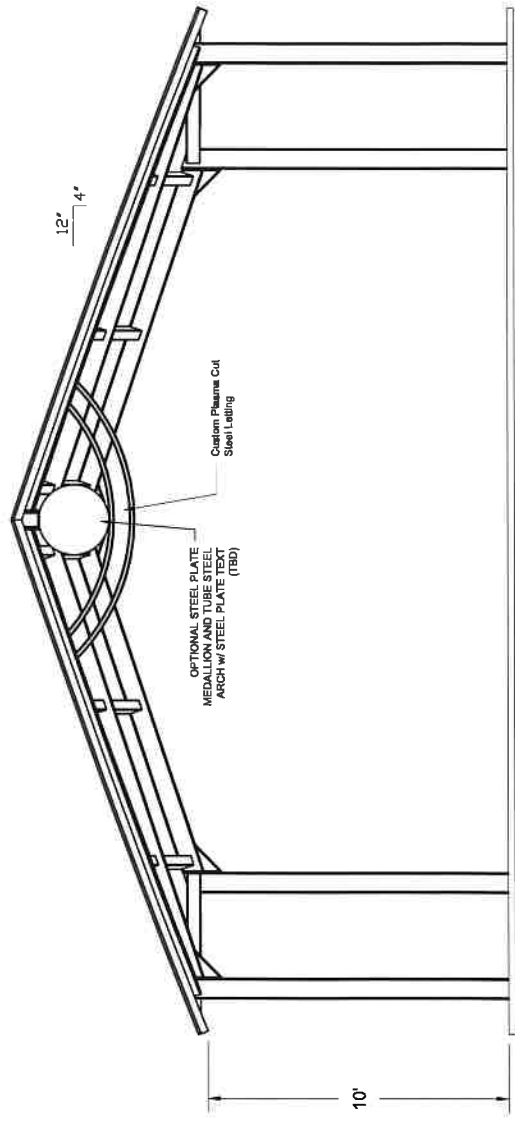
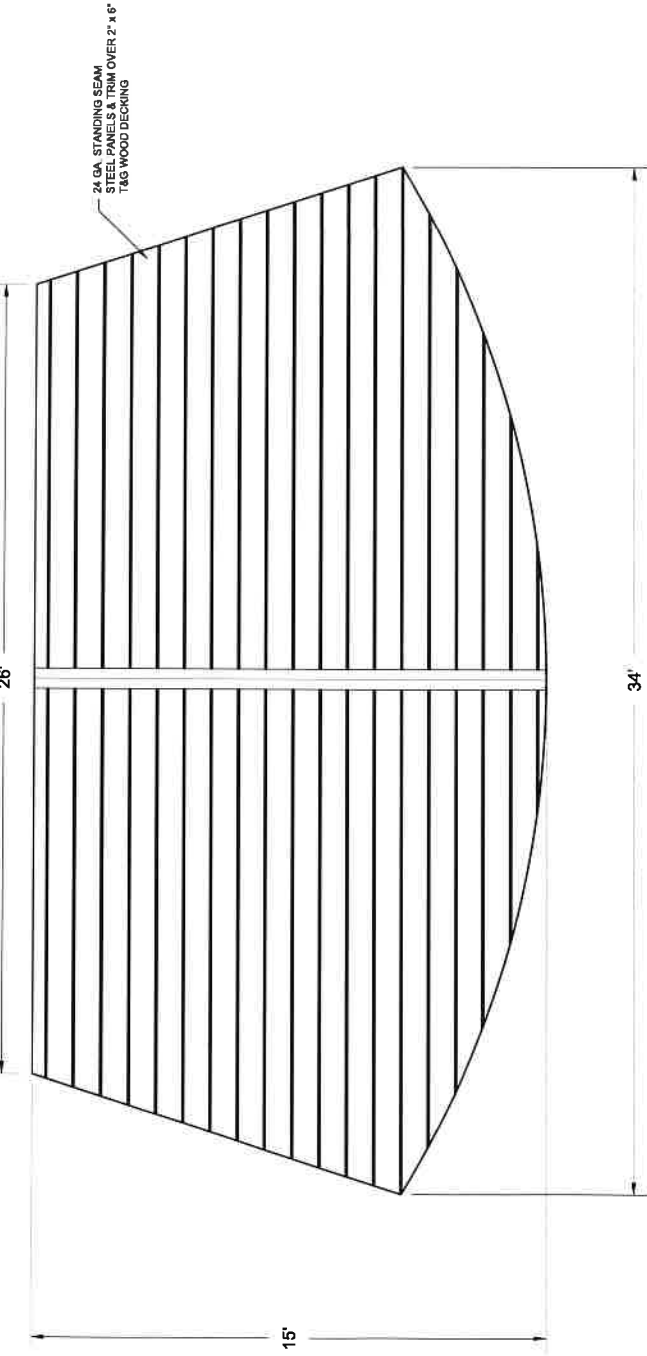

PH: 855-544-8439
www.ScenicShelters.com
ADDRESS: 7125 Heavilly Street SE #795, Ada, MI 49301

COPYRIGHT 2023
The information shown within this drawing is the intellectual property of Scenic Shelter, not be copied or disclosed to any unauthorized parties in part or its entirety without our written permission, and they shall not be used for construction.

NOTES:

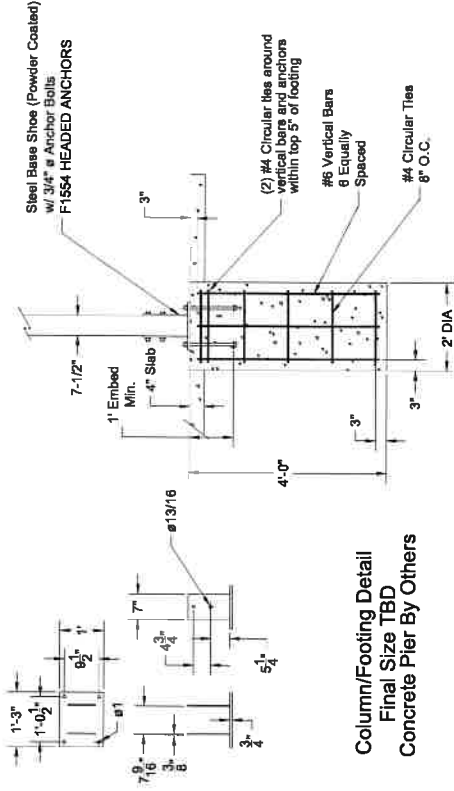

Column/Footing Detail
 Final Size TBD
 Concrete Pier By Others

